

# ORIGINAL

CITY OF BELLEVUE, WASHINGTON

ORDINANCE NO. 6115

AN ORDINANCE creating a new Chapter 23.85 to the Bellevue City Code to adopt the 2010 National Fire Protection Association Standard 130 for Fixed Guideway Transit and Passenger Rail Systems with amendments; and establishing an effective date.

WHEREAS, the International Fire and Building Codes do not specifically address the design or construction of light rail facilities; and

WHEREAS, the National Fire Protection Association Standard 130 was developed specifically to address life safety for passenger rail systems including stations; and

WHEREAS, the National Fire Protection Association Standard 130 has been used throughout the United States for the design and construction of passenger rail systems; now therefore

THE CITY COUNCIL OF THE CITY OF BELLEVUE, WASHINGTON, DOES ORDAIN AS FOLLOWS:

Section 1. A new Chapter 23.85 to the Bellevue City Code is hereby adopted to read as follows:

Sections:

23.85.100	Adoption – NFPA Standard 130
23.85.101	NFPA Standard 130 amended - Scope
23.85.103	NFPA Standard 130 amended – Limitations
23.85.104	NFPA Standard 130 amended – Equivalency
23.85.200	NFPA Standard 130 amended – Referenced Publications
23.85.301	NFPA Standard 130 amended – Definitions (General)
23.85.302	NFPA Standard 130 amended – Authority Having Jurisdiction (AHJ)
23.85.305	NFPA Standard 130 Section 3.2.2 amended – Building
23.85.335	NFPA Standard 130 Section 3.3.35 amended – Point of Safety
23.85.344	NFPA Standard 130 Section 3.3.44 amended – Station
23.85.407	NFPA Standard 130 Section 4.7 added – General Precautions
23.85.408	NFPA Standard 130 Section 4.8 added – Fire Service Features

23.85.409	NFPA Standard 130 Section 4.9 added – Building Services and Systems
23.85.410	NFPA Standard 130 Section 4.10 added – Interior Finishes
23.85.501	NFPA Standard 130 Section 5.1.1.1 amended – Occupancy
23.85.514	NFPA Standard 130 Section 5.1.1.4 added – Supplementary Accessibility Requirements
23.85.521	NFPA Standard 130 Section 5.2.1 amended – Safeguards During Construction
23.85.522	NFPA Standard 130 Section 5.2.2.1 amended – Building Construction
23.85.523	NFPA Standard 130 Section 5.2.3 amended – Compartmentation
23.85.531	NFPA Standard 130 Section 5.3.1 amended – Ventilation
23.85.541	NFPA Standard 130 Section 5.4.1 amended – Wiring Requirements
23.85.548	NFPA Standard 130 Section 5.4.8 amended – Emergency lighting and communication circuits
23.85.549	NFPA Standard 130 Section 5.4.11 amended – Emergency Power (Enclosed Stations)
23.85.550	NFPA Standard 130 Section 5.4.11.4 amended – Systems connected to emergency power
23.85.551	NFPA Standard 130 Section 5.5.1 amended – Means of Egress (General)
23.85.552	NFPA Standard 130 Section 5.5.1.3.3 added – Required Stairway in Enclosed Stations
23.85.554	NFPA Standard 130 Section 5.5.1.4 amended – Common Path of Travel
23.85.555	NFPA Standard 130 Section 5.5.1.5 amended – Horizontal Exits
23.85.556	NFPA Standard 130 Section 5.5.2.1 amended – Escalators
23.85.557	NFPA Standard 130 Section 5.5.5.1 amended – Occupant Load
23.85.558	NFPA Standard 130 Section 5.5.5.5 amended – Use by other than passengers or employees
23.85.610	NFPA Standard 130 Section 5.5.6.1 amended – Platform Evacuation
23.85.632	NFPA Standard 130 Section 5.5.6.3.2 amended – Stairs and Escalators
23.85.634	NFPA Standard 130 Section 5.5.6.3.4.3 amended – Emergency Exit Gates
23.85.635	NFPA Standard 130 Section 5.5.6.3.5.2 amended – Turnstile-type fare collection equipment
23.85.661	NFPA Standard 130 Section 5.5.6.1 amended – Means of Egress Illuminations
23.85.662	NFPA Standard 130 Section 5.5.6.2 amended – Emergency Lighting
23.85.670	NFPA Standard 130 Section 5.7.2.1 amended – Emergency

	Communications
23.85.672	NFPA Standard 130 Section 5.7.2.4 amended – Manual Fire Alarm Boxes
23.85.730	NFPA Standard 130 Section 5.7.3 amended – Automatic Sprinkler Systems
23.85.740	NFPA Standard 130 Section 5.7.4 amended – Standpipe and Hose Systems
23.85.750	NFPA Standard 130 Section 5.7.5 amended – Portable Fire Extinguishers
23.85.760	NFPA Standard 130 Section 5.9 amended – Interior Finishes
23.85.770	NFPA Standard 130 Section 6.2.1.9 amended – Trainway means of egress
23.85.780	NFPA Standard 130 Section 6.2.2.1 amended – Trainway exit stairs and doors
23.85.785	NFPA Standard 130 Section 6.2.5 amended – Enclosed Trainway Illumination
23.85.790	NFPA Standard 130 Section 6.3.1.1.3 amended – Trainway Walking Surfaces
23.85.795	NFPA Standard 130 Section 6.3.3.2.11 amended – Emergency Power -Enclosed Trainways
23.85.800	NFPA Standard 130 Section 6.5.2 amended – Standpipes - Enclosed Trainways
23.85.810	NFPA Standard 130 Section 7.2.4 amended – Emergency Ventilation System Design
23.85.820	NFPA Standard 130 Section 7.7.1 amended – Emergency Ventilation Power System Design
23.85.830	NFPA Standard 130 Section 8.8.3.1 amended – Trainway Illumination – Emergency Lighting
23.85.850	NFPA Standard 130 Section 10.3.2 amended – Emergency Responder Radio Coverage
23.85.860	NFPA Standard 130 Section 10.6.1 amended – Station Public Address System

#### Point of Information

An asterisk (\*) following the number or letter designating a paragraph indicates that explanatory material on the paragraph can be found in Annex A.

#### **23.85.100 Adoption - Standard for Fixed Guideway Transit and Passenger Rail Systems – NFPA 130**

NFPA Standard 130 2010 edition as published by the National Fire Protection Association and as amended, added to or excepted in this chapter is adopted by reference thereto as though fully set forth herein and shall be applicable within the

city. Not less than one copy of such code, appendices and standards, in the form in which it was adopted and suitably marked to indicate amendments, additions, deletions and exceptions as provided herein, shall be filed in the city clerk's office and shall be available for use and examination by the public.

**23.85.101 NFPA Standard 130 Section 1.1.1 amended – Scope**

Section 1.1.1 of NFPA Standard 130 is hereby amended to read as follows:

**1.1.1** This standard shall cover life safety from fire and fire protection requirements for underground, surface, and elevated fixed guideway transit and passenger rail systems, including but not limited to stations, trainways, emergency ventilation systems, vehicles, emergency procedures, communications, control systems and vehicle storage areas that are predominantly open to the atmosphere.

The administrative provisions of the International Fire Code (Chapter 1, Part 2, Sections 103 – 113 as amended in Bellevue City Code Chapter 23.11), and Bellevue City Code Chapter 23.05 (Construction Code Administration) apply in addition to the following administrative provisions.

NFPA 130 as adopted and amended by the City of Bellevue, is the primary applicable code, and other codes apply only as referenced herein, except that the fire marshal and building official shall have the authority to require design to other adopted codes where deemed appropriate. Wherever there are practical difficulties involved in carrying out the provisions of this code, the fire marshal and building official shall have the authority to grant modifications for individual cases, upon application of the owner or owner's representative, provided the fire marshal and building official shall first find that special individual reason makes the strict letter of this code impractical and the modification is in compliance with the intent and purpose of this code and that such modification does not lessen health, accessibility, life and fire safety, or structural requirements. The details of action granting modifications shall be recorded and entered in the appropriate permit files.

**23.85.103 NFPA Standard Section 1.1.3 amended - Limitations**

Section 1.1.3 of NFPA Standard 130 is hereby amended to read as follows:

**1.1.3 This standard shall not cover requirements for the following:**

- (1) Conventional freight systems
- (2) Buses and trolley coaches
- (3) Circus trains
- (4) Tourist, scenic, historic, or excursion operations
- (5) Any other system of transportation not included in the definition of fixed guideway transit (see 3.3.52.1) or passenger rail (see 3.3.52.2) system
- (6) Shelter stops

- (7) Ancillary facilities such as parking structures or vehicle maintenance facilities
- (8) Occupied building or structure areas not directly related to fixed guideway transit and passenger rail systems, as determined by the Fire Marshal and Building Official.

#### **23.85.104 NFPA Standard 130 Section 1.4 amended - Equivalency**

Section 1.4 of NFPA Standard 130 is hereby amended to read as follows:

**1.4\* Equivalency.**-The building official and the fire marshal shall have the authority to evaluate and approve or reject alternative materials, design and methods of construction and equipment. The provisions of this code are not intended to prevent the installation of any material or to prohibit any design or method of construction not specifically prescribed by this code; provided, that any such alternative has been approved. An alternative material, design or method of construction may be approved where the building official and fire marshal find that the proposed design is satisfactory and complies with the intent of the provisions of this code, and that the material, method or work offered is, for the purpose intended, at least the equivalent of that prescribed in the code in quality, strength, effectiveness, fire resistance, durability and life safety.

#### **23.85.200 NFPA Standard 130 Chapter 2 amended – Referenced Publications**

Chapter 2 of NFPA Standard 130 is hereby amended to read as follows:

**2.1 General.** The documents or portions thereof listed in this chapter are referenced within this standard and shall be considered part of the requirements of this document. Initial construction shall comply with the specific edition of each standard as listed herein. The applicable codes for future additions, alterations or repairs shall be determined by the building official and fire marshal.

**2.2 NFPA Publications.** National Fire Protection Association, 1 Batterymarch Park, Quincy, MA 02169

NFPA 10, Standard for Portable Fire Extinguishers, 2013 edition.

NFPA 13, Standard for the installation of Sprinkler Systems, 2013 edition.

NFPA 14, Standard for the installation of Standpipe and Hose Systems, 2013 edition.

NFPA 22, Standard for Water Tanks for Private Fire Protection, 2013 edition.

NFPA 25, Standard for the Inspection, Testing, and Maintenance of Water-Based Fire Protection Systems, 2011 edition.

NFPA 30, Flammable and Combustible Liquids Code, 2012 edition.

NFPA 70, National Electrical Code", 2014 edition.

NFPA 72, National Fire Alarm and Signaling Code, 2013 edition.

NFPA 91, Standard for Exhaust Systems for Air Conveying of Vapors, Gases, Mists, and Noncombustible Particulate Solids, 2010 edition.

NFPA 101®, Life Safety Code®, 2012 edition.  
NFPA 110, Standard for Emergency and Standby Power Systems, 2013 edition.  
NFPA 241, Standard for Safeguarding Construction, Alteration, and Demolition Operations, 2013 edition.  
NFPA 251, Standard Methods of tests of Fire Resistance of Building Construction and Materials, 2011 edition.  
NFPA 253, Standard Method. of Test for Critical Radiant flux of floor Covering Systems Using a Radiant Heat Energy Source, 2011 edition.  
NFPA 262, Standard Method of Test for flame travel and Smoke of Wires and Cables for Use in Air-Handling Spaces, 2011 edition.  
NFPA 286, Standard Methods of Fire Tests for Evaluating Contribution of Wall and Ceiling Interior Finish to Room Fire Growth, 2011 edition.  
NFPA 703, Standard for Fire Retardant-Treated Wood and Fire Retardant Coatings for Building Materials, 2012 edition.

### **2.3 Other Publications.**

**2.3.1 AMCA Publications.** Air Movement and Control Association International, Inc., 30 West University Drive, Arlington Heights, IL, 60004-1893.

AMCA 210, Laboratory Methods of Testing Fans for Certified Aerodynamic Performance Rating, 2007.

AMCA 250, Laboratory Methods of Testing Jet Tunnel Fans for Performance, 2005.

AMCA 300, Reverberant Room Method for Sound Testing of Fans, 2008.

**2.3.2 APTA Publications.** American Public Transportation Association, 1666 K Street NW, Washington, DC 20006.

APTA Standard SS-PS-002, Rev 2., 1998.

**2.3.3 ASHRAE Publications.** American Society of Heating, Refrigerating and Air Conditioning Engineers, Inc., 1791 Tullie Circle, N., Atlanta, GA 30329-2305.

ASHRAE Handbook - Fundamentals, 2009.

ASHRAE 149, Standard of Laboratory Methods of Testing Fans Used to Exhaust Smoke in Smoke Management Systems, 2009.

**2.3.4 ASTM Publications.** ASTM International, 100 Barr Harbor Drive, PO Box C700, West Conshohocken, PA, 19428-2959.

ASTM C 1166, Standard Test Method for Flame Propagation of Dense and Cellular Elastomeric Gaskets and Accessories, 1991.

ASTM E 1354 Standard Test Method for Heat and Visible Smoke Release Rates for Materials and Products Using an Oxygen Consumption Calorimeter

ASTM D 2724, Standard Test Method for Bonded, Fused, and Laminated Apparel Fabrics, 2011.

ASTM D 3574, Test I<sub>2</sub> (Dynamic Fatigue Test by the Roller Shear at Constant Force) or Test 1<sub>3</sub> (Dynamic Fatigue Test by Constant Force Pounding), 2008.

ASTM D 3675, Standard Test Method for Surface Flammability of Flexible Cellular Materials Using a Radiant Heat Energy Source, 2009.

- ASTM E 84, Standard Test Method for Surface Burning Characteristics of Building Materials, 2011.
- ASTM E 119, Standard Test Method for Fire Tests of Building Construction and Materials, 2011.
- ASTM E 136, Standard Test Method for Behavior of Materials in a Vertical Tube Furnace at 750°C, 2011.
- ASTM E 162, Standard Test Method for Surface Flammability of Materials Using a Radiant Heat Energy Source, 2011.
- ASTM E 648, Standard Test Method for Critical Radiant Flux of Floor-Covering Systems Using a Radiant Heat Energy Source, 2010.
- ASTM E 662, Standard Test Method for Specific Optical Density of Smoke Generated by Solid Materials, 2009.
- ASTM E 814, Standard Test Method for Fire Tests of Penetration Fire stop Systems, 2011.
- ASTM E 1354, Standard Test Method for Heat and Visible Smoke Release Rates for Materials and Products Using an Oxygen Consumption Calorimeter, 2011.
- ASTM E 1537, Standard Test Method for Fire Testing of Upholstered Furniture, 2007 .
- ASTM E 1590, Standard Test Method for Fire Testing of Mattresses, 2007.
- ASTM E 2061, Standard Guide for Fire Hazard Assessment of Rail Transportation Vehicles, 2009.

- 2.3.6 ICEA Publications.** Insulated Cable Engineers Association, P. O. Box 1568, Carrollton, GA30112.
- ICEA S-73-532/NEMA WC-57, Standard for Control, Thermocouple Extension, and Instrumentation Cables, 2004.
  - ICEA S-95-658/NEMA. WC-70, Power Cables Rated 2000 Volts or Less for the Distribution of Electrical Energy,

- 2.3.8 IEEE Publications.** Institute of Electrical and Electronics Engineers, Three Park Avenue, 17th Floor, New York, NY 10016-5997.
- IEEE II, Standard for Rotating Electric Machinery for Rail and Road Vehicles, 2000.
  - IEEE 16, American Standard for Electric Control Apparatus for Land Transportation Vehicles, 2004.
  - IEEE 383, Standard for Qualifying Class 1E Electric Cables and Field Splices for Nuclear Power Generating Stations, 2003.
  - IEEE 1202, Standard for Flame-Propagation Testing of Wire & Cable, 2006.

- 2.3.9 UL Publications.** Underwriters Laboratories Inc., 333 Pfingsten Road, Northbrook, IL 60062-2096.
- ANSI/UL 44, Standard for Safety Rubber-Insulated Wires and Cables, 2010
  - ANSI/UL 83, Standard for Safety Thermoplastic-Insulated Wires • and Cables, 2008
  - ANSI/UL 1685, Standard for Vertical-Tray Fire-Propagation and Smoke-Release Test for Electrical and Optical-Fiber Cables, 2007.
  - ANSI/UL 2196, Standard for Tests for Fire Resistive Cables, 2001. Revised December 2006.

## **2.4 References for Extracts in Mandatory Sections.**

- NFPA 72, National Fire Alarm and Signaling Code, 2013 edition.
- NFPA 101, Life Safety Code®, 2012 edition.
- NFPA 253, Standard Method of Test for Critical Radiant Flux of Floor Covering Systems Using a Radiant Heat Energy Source, 2011 edition.
- NFPA 271, Standard Method of Test for Heat and Visible Smoke Release Rates for Materials and Products Using an Oxygen Consumption Calorimeter, 2009 edition.
- NFPA 402, Guide for Aircraft Rescue and Fire-Fighting Operations, 2008 edition.
- NFPA 472, Standard for Competence of Responders to Hazardous Materials/Weapons of Mass Destruction Incidents, 2008 edition.
- NFPA 502, Standard for Road Tunnels, Bridges, and Other Limited Access Highways, 2011 edition.
- NFPA 921, Guide [or Fire and Explosion Investigations, 2011 edition.

## **2.5 Bellevue City Codes (BCC)**

- Building Code (International Building Code as adopted and amended by the City of Bellevue – BCC 23.10). 2012 edition
- Electrical Code (Washington Cities Electrical Code as adopted and amended by the City of Bellevue – BCC 23.30, 2009 edition
- Fire Code (International Fire Code as adopted and amended by the City of Bellevue – BCC 23.11). 2012 edition
- Mechanical Code (International Mechanical Code as adopted and amended by the City of Bellevue – BCC 23.50), 2012 edition
- Plumbing Code (Uniform Plumbing Code as adopted and amended by the City of Bellevue – BCC 23.60), 2012 edition
- Clearing and Grading Code (BCC – 23.76)

### **23.85.301 NFPA Standard 130 Section 3.1 amended – Definitions (General)**

Section 3.1 of NFPA Standard 130 is hereby amended to read as follows:

**3.1 General.** The definitions contained in this chapter, the International Fire Code Chapter 2 and the International Building Code Chapter 2 shall apply to the terms used in this Chapter. Where terms are not defined in this chapter or within another chapter, they shall be defined using their ordinarily accepted meanings within the context in which they are used. Merriam-Webster's Collegiate Dictionary, 11th edition, shall be the source for the ordinarily accepted meaning.

### **23.85.302 NFPA Standard 130 Section 3.2.2 amended – Authority Having Jurisdiction (AHJ)**

Section 3.2.2 of NFPA Standard 130 is hereby amended to read as follows:

**3.2.2\* Authority Having Jurisdiction (AHJ).** City of Bellevue building official, fire marshal or other designated authority charged with the administration and enforcement of the adopted codes.

### **23.85.305 NFPA Standard 130 Section 3.2.2 amended – Building**



Section 3.3.5 of NFPA Standard 130 is hereby amended to read as follows:

**3.3.5 Building.** Any structure used or intended for supporting or sheltering any use or occupancy.

**23.85.335 NFPA Standard 130 Section 3.3.35 amended – Point of Safety**

Section 3.3.35 of NFPA Standard 130 is hereby amended to read as follows:

**3.3.35 Point of Safety.** A point of safety is one of the following: (1) an enclosed fire rated exit as defined by the International Building Code that leads to a public way or safe location outside the station, trainway, or vehicle; (2) an at-grade point not less than 50' beyond the vehicle, enclosing station, or trainway\_in accordance with International Building Code 1027.5; (3) any other approved location.

**23.85.344 NFPA Standard 130 Section 3.3.44 amended – Station**

Section 3.3.44 of NFPA Standard 130 is hereby amended to read as follows:

**3.3.44 Station.** A place designated for the purpose of loading and unloading passengers, including patron service areas and ancillary spaces associated with the same structure.

**3.3.44.1 Enclosed Station.** A station or portion thereof that does not meet the definition of an open station.

**3.3.44.2\* Open Station.** A station that is constructed such that it is directly open to the atmosphere and smoke and heat are allowed to disperse directly into the atmosphere. Open stations shall conform to the design requirements of sections 3.3.44.2.1 through 3.3.44.2.2

**3.3.44.2.1 – Roof/Canopy Extent.** For a station to be considered "open to the atmosphere" the roof of the station shall comply with the following:

- (1) There shall be no roof directly above the trainway for the entire length of the station.
- (2) Individual roof segments covering the full width of the platform (within 36 inches of platform edge) shall not exceed 200 feet in length without a minimum separation of 20 feet from adjoining full width roof segments. For the purposes of determining canopy length, individual canopy segments covering the full width of the platform (within 36 inches of platform edge) spaced closer than 20 feet to each other shall be considered as one canopy.

**Exception:** In an open station provided with an automatic fire sprinkler system per NFPA 13, a roof, canopy, or ceiling extending the full width of the platform shall be permitted to be the full length of the platform.

**Exception:** Roof segments which remain farther than 36 inches from the platform edge may be the full length of the station.

- (3) The underside of the ceiling shall be at a minimum height of 10 feet above the platform, with a minimum slope of 1.5:12 to facilitate smoke venting to the atmosphere. There shall be a minimum 12 inch clearance between the edge of the roof and the static envelope of a train. Roof components perpendicular to the roof slope with a depth no greater than 6 inches may project into the minimum height of the underside of the ceiling plane. (Fig. A)

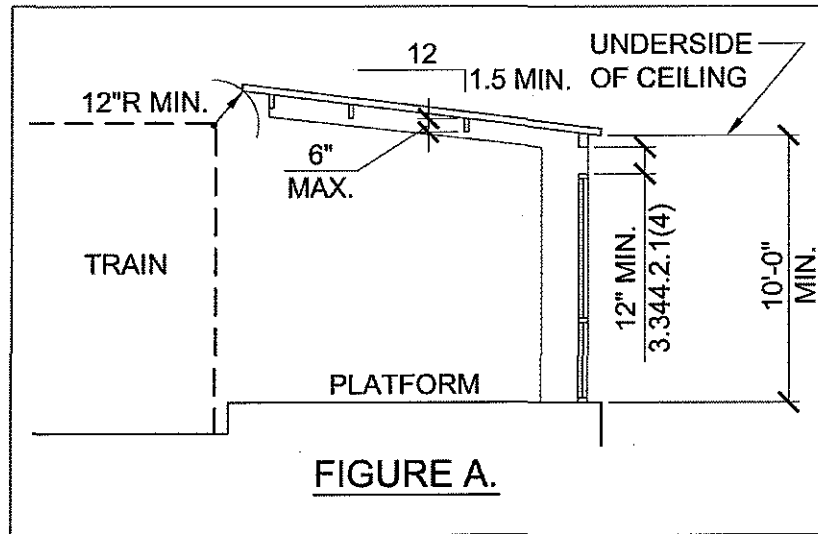

The bottom of roof components perpendicular to the roof slope with a depth greater than 6 inches shall establish the height of the underside of the ceiling plane (Fig. B) unless there is a minimum 6 inch high gap between these components and the underside of the ceiling plane. (Fig. C)

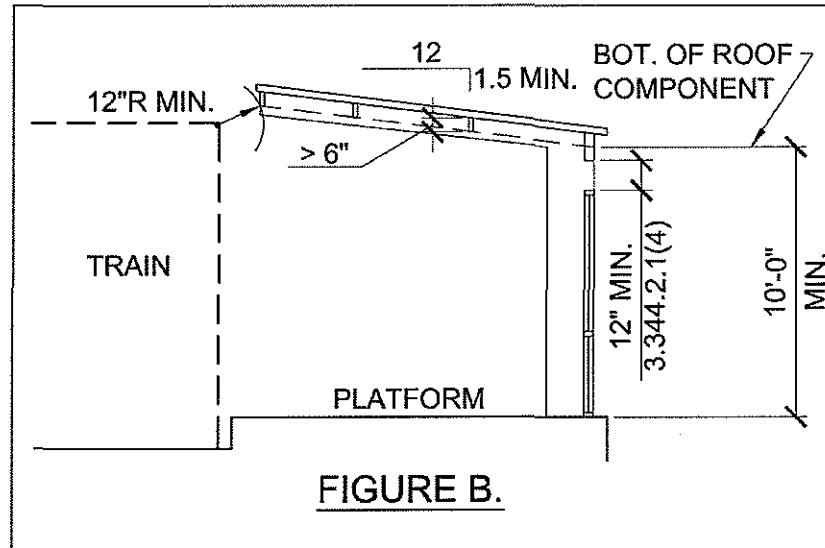

The bottom of roof components shall comply with the minimum height requirements of the International Building Code.

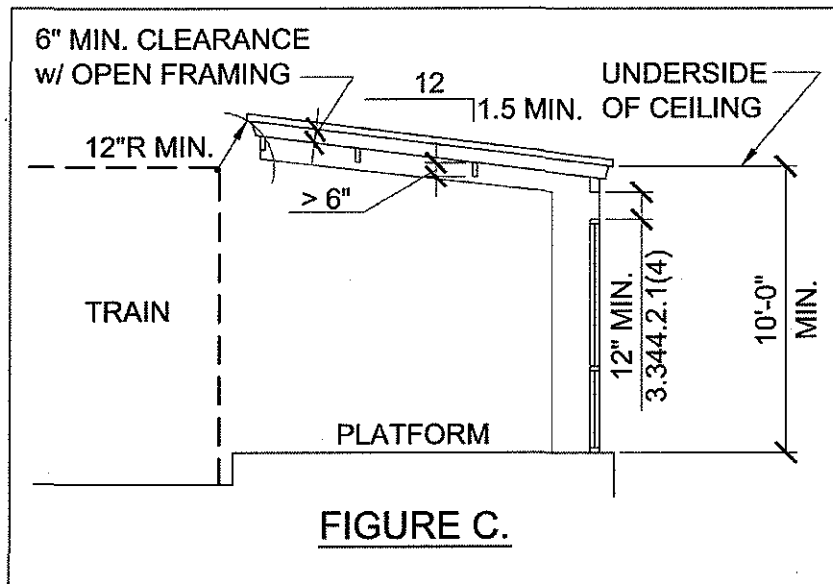

- (4) At side platform stations there shall be a minimum 12 inch high gap between the canopy/ceiling and solid walls/windcreens along the side opposite of the tracks for a minimum 60% of the length of the roof. (Fig. A, B, or C)

3.3.44.2.2 – Individual freestanding components (windscreen shelters, kiosks, etc.) on the passenger platform shall extend no closer than 12 inches to the underside of the roof/ceiling assembly or provide equivalent opening area to allow smoke to escape to the atmosphere.

3.3.44.2.3 – *Retained Cut Stations.* Portions of a station in a retained cut complying with 3.3.44.2.1 shall be considered as an open station. Where the

station is covered with structures having a width greater than 20 feet crossing both the platforms and trainway with a minimum clearance of 16 feet above the platform to the underside of the body of the structure (excluding structural components) that portion of the station shall be provided with an automatic fire sprinkler system per NFPA 13 and continue to be considered an open station. Otherwise the covered portion shall be considered an enclosed station. Where a station is covered by a structure crossing the platform and trainway exceeding 200 feet in width, that portion of the station shall be considered an enclosed station.

3.3.44.2.4 – *Opening Protection*. Openings and the exterior walls of “open stations” (not including edges of trainways) shall also comply with the requirements of Table 602, Section 704.10 and Section 705 of the International Building Code.

#### **23.85.407 NFPA Standard 130 Section 4.7 added – General Precautions**

Chapter 4 of NFPA Standard 130 is hereby amended by the addition of a new Section 4.7 to read as follows:

**4.7 General Precautions.** International Fire Code Chapter 3 shall govern the occupancy and maintenance for precautions against fire and spread of fire and general requirements for fire safety.

#### **23.85.408 NFPA Standard 130 Section 4.8 added – Fire Service Features**

Chapter 4 of NFPA Standard 130 is hereby amended by the addition of a new Section 4.8 to read as follows:

**4.8 Fire Service Features.** International Fire Code Chapter 5 shall govern fire service features for trainways, stations and tunnels.

**Exception:** Fire apparatus access is not required for trainways or tunnels except as otherwise determined by NFPA 130, section 6.2.3.

#### **23.85.409 NFPA Standard 130 Section 4.9 added – Building Services and Systems**

Chapter 4 of NFPA Standard 130 is hereby amended by the addition of a new Section 4.9 to read as follows:

**4.9 Building Services and Systems.** International Fire Code Chapter 6 shall apply to the installation, operation and maintenance of fuel-fired appliances and heating systems, emergency and standby power systems, electrical systems and equipment, mechanical refrigeration systems, elevator recall, stationary storage battery systems and commercial kitchen equipment.

#### **23.85.410 NFPA Standard 130 Section 4.10 added – Interior Finishes**

Chapter 4 of NFPA Standard 130 is hereby amended by the addition of a new Section 4.10 to read as follows:

**4.10 Interior Finishes.** International Fire Code Chapter 8 shall govern interior finish,

interior trim, furniture, furnishings, decorative materials and decorative vegetation in stations and tunnels.

**23.85.501 NFPA Standard 130 Section 5.1.1.1 amended – Occupancy**

Section 5.1.1.1 of NFPA Standard 130 is hereby amended to read as follows:

**5.1.1.1** The primary purpose of a station shall be for the use of the passengers who normally stay in a station structure for a period of time no longer than that necessary to wait for and enter a departing passenger-carrying vehicle or to exit the station after arriving on an incoming passenger-carrying vehicle.

**5.1.1.1.1** Fixed guideway transit and passenger rail stations are classified as Group A, Division 3 occupancies in accordance with the *International Building Code*

**5.1.1.1.2** Enclosed and elevated fixed guideway transit and passenger rail stations shall be posted with the maximum occupant load in accordance with Section 1004.3 of the *International Building Code*.

**23.85.514 NFPA Standard 130 Section 5.1.1.4 added – Supplementary Accessibility Requirements**

Section 5.1.1.1 of NFPA Standard 130 is hereby amended by the addition of a new subsection 5.1.1.4 to read as follows:

**5.1.1.4** Fixed guideway transit and passenger rail stations shall comply with the applicable provisions of the *International Building Code* Appendix "E" Section, E109

**23.85.521 NFPA Standard 130 Section 5.2.1 amended – Safeguards During Construction.**

Section 5.2.1 of NFPA Standard 130 is hereby amended to read as follows:

**5.2.1 Safeguards During Construction.** During the course of construction or major modification of any structure, provisions of Chapter 33 of the *International Fire Code* and Chapter 33 of the *International Building Code* shall apply.

**23.85.522 NFPA Standard 130 Section 5.2.2.1 amended – Building Construction**

Section 5.2.2 of NFPA Standard 130 is hereby amended to read as follows:

**5.2.2.1** Building construction for all new enclosed stations shall be not less than Type I or Type II or combinations of Type I and Type II noncombustible construction as defined in Chapter 6 of the *International Building Code*, for the station configuration, or as determined by an engineering analysis of potential fire exposure hazards to the structure.

**5.2.2.2** Other types of construction are permitted for open stations in accordance with the provisions of Chapter 6 of the *International Building Code* for corresponding station configurations.

**5.2.2.3** Where access for firefighting is restricted, standpipes sized to provide 1000 gpm shall be provided. Hydraulic calculations shall be based on 500 gpm at 150 psi at the hydraulically most remote hose connection, with a simultaneous flow of 500 gpm at the next hydraulically most remote hose connection. The maximum calculated pressure at any point in the system shall not exceed 350 psi. Hose connection outlets shall be provided at maximum 200 feet spacing.

**5.2.2.4\*** Illumination levels of enclosed stations shall not be less than .25 ft-candles at the walking surface.

### **23.85.523 NFPA Standard 130 Section 5.2.3 amended – Compartmentation**

Section 5.2.3. of NFPA Standard 130 is hereby amended to read as follows:

**5.2.3.1.1\* Passenger Stairs and Escalators.** Stairs and escalators regularly used by passengers for circulation during normal revenue service in enclosed stations equipped throughout with an automatic sprinkler system are not required to be enclosed.

**5.2.3.1.2 Open Stations.** Public areas on different levels in open stations are permitted to be interconnected.

**5.2.3.1.3 Enclosed Stations.** Public areas on different levels in enclosed stations shall be permitted to be interconnected, provided fire separation is not required for smoke control or other fire protection purposes.

**5.2.3.2\* Separation Between Public and Nonpublic Floor Areas.** All public areas shall be separated from adjacent nonpublic areas by noncombustible construction except as required in Chapter 5 of the *International Building Code*.

**5.2.3.3 Ancillary Spaces.** Fire resistance ratings of separations between ancillary occupancies shall be established in accordance with Chapters 3, 5 & 7 of the *International Building Code*.

### **23.85.531 NFPA Standard 130 Section 5.3.1 amended – Ventilation**

Section 5.3.1. of NFPA Standard 130 is hereby amended to read as follows:

**5.3.1** A smoke control system shall be provided in underground passenger rail stations in accordance with Section 909 of the *International Building Code* as amended by Bellevue City Code. Smoke control shall restrict movement of smoke to the general area of fire origin and non-occupied exhaust areas and maintain tenability in the means of egress.

### **23.85.541 NFPA Standard 130 Section 5.4.1 amended – Wiring Requirements**

Section 5.4.1. of NFPA Standard 130 is hereby amended to read as follows:

**5.4.1** All wiring materials and installations within stations other than for traction power shall conform to requirements of NFPA 70, the Washington Cities Electrical Code and, in addition, shall satisfy the requirements of 5.4.2 through 5.4.9.

**23.85.548 NFPA Standard 130 Section 5.4.8 amended – Emergency lighting and communication circuits**

Section 5.4.8. of NFPA Standard 130 is hereby amended to read as follows:

**5.4.8** The emergency lighting and communications circuits shall be protected from physical damage by system vehicles or other normal system operations and from fires in the system for a period of not less than 1 hours. The circuits shall be protected from ASTM E 119 fire conditions as required in NFPA 70 (2008) Article 700, Part II 700.9.D(1).

**23.85.549 NFPA Standard 130 Section 5.4.11 amended – Emergency Power (Enclosed Stations)**

Section 5.4.11. of NFPA Standard 130 is hereby amended to read as follows:

**5.4.11 Emergency Power – Enclosed Stations.** Enclosed stations shall be such that, in the event of failure of the normal supply to or within, the system, standby (legally required) and emergency power in accordance with Bellevue City Code Section 23.10.403, Article 700 of NFPA 70 as amended by the Washington Cities Electrical Code, and Chapter 4 of NFPA 110 and the following special provisions:

Power distribution from the emergency source to the emergency transfer switch shall be by an independent route from the normal power source.

If the emergency power system is a generator set inside a building, the system shall be located in a separate room enclosed with 2-hour fire barriers constructed in accordance with International Building Code Section 707 or horizontal assemblies constructed in accordance with International Building Code Section 712, or both, and shall be in a separate room from the normal power source including transformers and distribution equipment.

If the emergency power system is a generator then system supervision with manual start and transfer features shall be provided at the fire command center.

Fire pumps shall comply with NFPA 20 and NFPA 70 Article 695.

The supply system for emergency purposes, in addition to the normal services to the station, shall be one or more of the types of systems described in subsections 700.12(A) through 700.12(E) of NFPA 70.

**23.85.550 NFPA Standard 130 Section 5.4.11.4 amended – Systems connected to emergency power**

Section 5.4.11.4. of NFPA Standard 130 is hereby amended to read as follows:

5.4.11.4 Systems identified in Bellevue Building Code Section 23.10.403 shall be connected to the emergency power system

**23.85.551 NFPA Standard 130 Section 5.5.1 amended – Means of Egress (General)**

Section 5.5.1. of NFPA Standard 130 is hereby amended to read as follows:

**5.5.1\* General.** The provisions for means of egress for a station shall comply with Section 5.5 and the following International Building Code provisions, except as herein modified;

Maintenance of the means of egress (MOE) system; 1001.2, 1001.3, 1020.1  
Ceiling height; 1003.2, 1009.5  
Protruding objects and encroachment; 1003.3, 1005.7  
Elevation changes; 1003.5  
MOE system continuity; 1003.6, 1005.4, 1021.1  
Posting the maximum occupant load; 1004.3, Posting the maximum occupant load sign is required in enclosed and elevated stations in spaces with a total occupant load of 50 or more as determined by section 5.5.1, item (2).  
Outdoor areas; 1004.5, except for at-grade stations  
Multiple occupancies; 1004.6, 1014.2.1, 1021.2.1  
Egress width and capacity; 1005.2, 1005.3, 1005.5, 1005.6, 1009.4  
Accessible means of egress; 1007  
Doors, gates, turnstiles and door hardware; 1008  
Stairway design; 1009  
Ramp design; 1010  
General signage; 1007.9, 1007.10, 1008.1.9.3, 1008.1.9.7, 1008.1.9.8, 1022.9  
Exit signs; 1011 Exception: Exit signs are not required for at-grade platform stations  
Handrail design; 1003.5, 1005.7.2, 1009.12, 1009.15, 1010.9, 1010.10.2, 1012, 1013.3, 1024.2.3, 1028.6.1, 1028.9.1, 1028.10.1, 1028.13  
Guard rail design; 1013  
Arrangement of exits (exit spread); 1015.2  
Boiler, incinerator, furnace, refrigeration machinery and refrigerated rooms; 1015.3 through 1015.5.  
Number of exits or exit access doorways from spaces; 1015.1, except for at-grade open stations  
Corridor design; 1018  
Egress balcony design; 1019  
Exit design; 1020  
Number of exits or exit access doorways from stories; 1021  
Intervening rooms, areas and spaces; 1004.1.1, 1014.2, 1018.6  
Interior stairway and ramps; 1022  
Exit passageways; 1023



Exterior exit stairways and ramps; 1026  
Exit discharge; 1027

**23.85.552 NFPA Standard 130 Section 5.5.1.3.3 added – Required Stairway in Enclosed Stations**

Section 5.5.1.3 of NFPA Standard 130 is hereby amended by the addition of a new subsection 5.5.1.3.3 to read as follows:

**5.5.1.3.3** Every required stairway in enclosed stations serving floor levels more than 30 feet (9144 mm) below its level of exit discharge, except those regularly used by passengers shall comply with the requirements for a smokeproof enclosure in Section 1022.10 of the *International Building Code*.

**23.85.554 NFPA Standard 130 Section 5.5.1.4 amended – Common Path of Travel**

Section 5.5.1.4 of NFPA Standard 130 is hereby amended to read as follows:

**5.5.1.4\* Common Path of Travel.** A common path of travel shall be in accordance with the International Building Code.

**23.85.555 NFPA Standard 130 Section 5.5.1.5 amended – Horizontal Exits**

Section 5.5.1.5 of NFPA Standard 130 is hereby amended to read as follows:

**5.5.1.5\*** Horizontal exits shall be in accordance with International Building Code Section 1025

**23.85.556 NFPA Standard 130 Section 5.5.2.1 amended – Escalators**

Section 5.5.2.1 of NFPA Standard 130 is hereby amended to read as follows:

**5.5.2.1** Escalators may be permitted as a means of egress in stations, provided they account for not more than 25% of the required number and capacity of the means of egress at any one level and the following criteria are met:

- (1)\*The escalators shall be constructed of noncombustible materials
- (2)\*Escalators running in the direction of egress shall be permitted to remain operating
- (3) Escalators running reverse to the direction of egress shall be capable of being stopped locally and remotely as follows:
  - (a) Locally by manual stopping device at the escalator
  - (b) Remotely by one of the following:
    - i. A manual stopping device at a remote location
    - ii. As part of a pre-planned evacuation response
- (4)\* Where provision is made for remote stopping of escalators counted as means of egress, where one of the following shall apply:
  - (a) The stop shall be delayed until it is preceded by a minimum 15-second audible signal, or warning message sounded at the escalator
  - (b) Where escalators are equipped with the necessary controls to deceleration a controlled manner under the full rated load, the stop shall be

delayed for at least 5 seconds before beginning deceleration and the deceleration rate shall be no greater than 0.052 m/sec<sup>2</sup> (0.17ft./sec<sup>2</sup>).

- (5) Where an audible signal or warning message is used, the following shall apply:
- (a) The signal or message shall have a sound intensity that is at least 15 dBA above the average ambient sound level for the entire length of the escalator.
  - (b) The signal shall be distinct from the fire alarm signal.
  - (c) The warning message shall meet audibility and intelligibility requirements.

**23.85.557 NFPA Standard 130 Section 5.5.5.1 amended – Occupant Load**

Section 5.5.5.1 of NFPA Standard 130 is hereby amended to read as follows:

**5.5.5.1** The occupant load for a station shall be computed as follows:

- (1) For the purpose of determining timed egress analysis, the train load of trains simultaneously entering the station on all tracks in normal traffic direction plus the simultaneous entraining load awaiting a train.
- (2) For the purpose of determining the number of required exits and the minimum egress width, the number of occupants computed at the rate of one occupant per unit of area as follows:
  - 7 sq. ft. net for public areas in enclosed stations unless otherwise approved by the building official.
  - 15 sq. ft. net for public areas in surface structures and elevated structures unless otherwise approved by the building official.
  - 30 sq.ft. gross for mercantile
  - 100 sq.ft. gross for business areas
  - 300 sq.ft. gross for storage areas, and mechanical equipment rooms
  - Occupant loads for other uses shall be determined by the building official

*Note: Compliance with both timed performance and area based occupant load determination per items 1) and 2 is required.*

**23.85.558 NFPA Standard 130 Section 5.5.5.5 amended – Use by other than passengers or employees**

Section 5.5.5.5 of NFPA Standard 130 is hereby amended to read as follows:

**5.5.5.5** If an area within a station is intended for use by other than passengers or employees, the occupant load for that area shall be determined in accordance with the provisions of Chapter 10 of the *International Building Code*

**23.85.610 NFPA Standard 130 Section 5.5.6.1 amended – Platform Evacuation**

Section 5.5.6.1 of NFPA Standard 130 is hereby amended to read as follows:

**5.5.6.1\* Platform Evacuation.** There shall be sufficient egress capacity to evacuate the platform occupant load as defined in 5.5.5.6 from the station platform in 4 minutes or less, but in no case shall the required egress width be less than prescribed by Section 1005 of the International Building Code, except as modified in this section.

**5.5.6.1.1** For open stations the maximum travel distance on the platform to a point at which a means of egress route leaves the platform shall not exceed 100 m (325 ft). For enclosed stations, the limits established in Section 1016 of the International Building Code shall apply.

**5.5.6.1.2\*** Modification of the evacuation time and travel distance shall be permitted based on an engineering analysis by evaluating material heat release rates, station geometry, and emergency ventilation systems.

### **23.85.632 NFPA Standard 130 Section 5.5.6.3.2 amended – Stairs and Escalators**

Section 5.5.6.3.2 of NFPA Standard 130 is hereby amended to read as follows:

**5.5.6.3.2.1** For enclosed stations, no less than 2 stairways shall be enclosed, and separated by not less than 75% of the longest diagonal dimension of the platform, and not less than 60% of the capacity of the means of egress shall be of enclosed stairways not less than 60" in width.

**5.5.6.3.2.2\*** Escalators may only be permitted to be used as a means of egress as provided for in this section.

**5.5.6.3.2.3\*** Capacity and travel speed for stairs and escalators shall be computed as follows:

- (1) Capacity – 0.0555 //mm-min (1.41 pim)
- (2) \*Travel speed – 15 m/min (48 (fpm) (indicates vertical component of travel speed)

**5.5.6.3.2.4\*** Escalators may account for up to 25% of the required number and capacity of the means of egress at any one level

**5.5.6.3.2.5** Escalators may be permitted to account for up to 25% of the required number and capacity of the means of egress at any one level for purposes of calculating platform evacuation time where the following criteria are met:

- (1) The escalators are capable of being remotely brought to a stop in accordance with the requirements of 5.5.2.1(3)(b), 5.5.2.1(4), and 5.5.2.1(5).
- (2) A portion of the means of egress capacity from each station level is comprised of stairs.
- (3) For enclosed stations, at least one enclosed exit stair or exit passageway shall provide continuous access from the platforms to a public way.

**5.5.6.3.2.6\*** In calculating the egress capacity of escalators, one escalator at each level shall be considered as being out of service.

**5.5.6.3.2.7** The escalator chosen shall be the one having the most adverse

effect upon egress capacity.

**23.85.634 NFPA Standard 130 Section 5.5.6.3.4.3 amended – Emergency Exit Gates**

Section 5.5.6.3.4.3 of NFPA Standard 130 is hereby amended to read as follows:

**5.5.6.3.4.3** Emergency exit gates shall comply with Chapter 10 of the *International Building Code*, and the clear width of the exit walkway shall be maintained.

**23.85.635 NFPA Standard 130 Section 5.5.6.3.5.2 amended – Turnstile-type fare collection equipment**

Section 5.5.6.3.5.2 of NFPA Standard 130 is hereby amended to read as follows:

**5.5.6.3.5.2** Turnstile-type fare collection equipment shall be permitted in accordance with Chapter 10 of the *International Building Code* and shall account for a capacity of 25 ppm for egress calculations.

**23.85.661 NFPA Standard 130 Section 5.5.6.1 amended – Means of Egress Illuminations**

Section 5.6.1 of NFPA Standard 130 is hereby amended to read as follows:

**5.6.1** Illumination of the means of egress in stations shall be in accordance with Section 1006 of the *International Building Code*, except as otherwise noted herein.

**23.85.662 NFPA Standard 130 Section 5.5.6.2 amended – Emergency Lighting**

Section 5.6.2 of NFPA Standard 130 is hereby amended to read as follows:

**5.6.2** Means of egress shall be provided with a system of emergency lighting in accordance with Section 1006.3 of the *International Building Code*, except as otherwise noted herein.

**23.85.670 NFPA Standard 130 Section 5.7.2.1 amended – Emergency Communications**

Section 5.7.2.1 of NFPA Standard 130 is hereby amended to read as follows:

**5.7.2.1** A public address (PA) system and emergency voice alarm reporting devices, such as emergency telephone boxes or manual fire alarm boxes conforming to *NFPA 72*, shall be required in stations. Emergency Responder radio coverage shall be provided throughout all fixed guideways, tunnels, stations and ancillary spaces in accordance with Bellevue City Code Section 23.11.510 and 23.11.1103.2

**23.85.672 NFPA Standard 130 Section 5.7.2.4 amended – Manual Fire Alarm Boxes**

Section 5.7.2.4 of NFPA Standard 130 is hereby amended to read as follows:

**5.7.2.4 Manual Fire Alarm Boxes.** Manual fire alarm boxes shall be installed in accordance with International Fire Code Section 907.4.2.

**Exception** – Where approved by the *Fire Marshal*, emergency alarm reporting devices may be utilized in lieu of manual fire alarm boxes.

**23.85.730 NFPA Standard 130 Section 5.7.3 amended – Automatic Sprinkler Systems**

Section 5.7.3 of NFPA Standard 130 is hereby amended to read as follows:

**5.7.3.1** An automatic sprinkler protection system shall be provided in all areas of stations used for concessions, in storage areas, in trash rooms, and in the steel truss area of all escalators and other similar areas with combustible loadings, except trainways.

**5.7.3.1.1** An automatic sprinkler system shall be provided throughout all areas of enclosed underground fixed guideway transit and passenger rail stations.

**5.7.3.2** Sprinkler protection shall be permitted to be omitted in areas of open stations.

**5.7.3.3** A sprinkler system waterflow alarm and supervisory signal service shall be installed.

**5.7.3.4** Other fire suppression systems, if approved, may be substituted for automatic sprinkler systems

**5.7.3.5** Automatic fire sprinkler systems shall be tested and maintained in accordance with NFPA 25

**23.85.740 NFPA Standard 130 Section 5.7.4 amended – Standpipe and Hose Systems**

Section 5.7.4 of NFPA Standard 130 is hereby amended to read as follows:

**5.7.4 Standpipe and Hose Systems.** Standpipes shall comply with International Fire Code Section 905 as amended by Bellevue City Code Chapter 23.11 and this section

**23.85.750 NFPA Standard 130 Section 5.7.5 amended – Portable Fire Extinguishers**

Section 5.7.5 of NFPA Standard 130 is hereby amended to read as follows:

**5.7.5 Portable Fire Extinguishers.** Portable fire extinguishers in such number, size, type, in accordance with International Fire Code Section 906

**23.85.760 NFPA Standard 130 Section 5.9 amended – Interior Finishes**

Section 5.9 of NFPA Standard 130 is hereby amended to read as follows:

**5.9.1.1** Interior wall, floor and ceiling finish materials in enclosed stations shall either be noncombustible or shall comply with Chapter 8 of the International Fire Code

**5.9.2.1** Interior finish in open stations shall comply with the requirements of Chapter 8 of the International Fire Code.

**23.85.770 NFPA Standard 130 Section 6.2.1.9 amended – Trainway means of egress**

Section 6.2.1.9 of NFPA Standard 130 is hereby amended to read as follows:

**6.2.1.9\*** The means of egress within the trainway shall be provided with an unobstructed clear width graduating from the following:

- (1) 610 mm (30 in.) at the walking surface to
- (2) 760 mm (36 in.) at 1420 mm (56 in.) above the walking surface and to
- (3) 610 mm (30 in.) at 2025 mm (80 in.) above the walking surface

**23.85.780 NFPA Standard 130 Section 6.2.2.1 amended – Trainway exit stairs and doors**

Section 6.2.2.1 of NFPA Standard 130 is hereby amended to read as follows:

**6.2.2.1 General.** Exit stairs and doors shall comply with Chapter 10 of *International Building Code*, except as herein modified.

**23.85.785 NFPA Standard 130 Section 6.2.5 amended – Enclosed Trainway Illumination**

Section 6.2.5 of NFPA Standard 130 is hereby amended to read as follows:

**6.2.5.2** Lighting systems for enclosed trainways described in 6.2.5.1 shall be installed in accordance with Chapter 10 of the International Building Code, except as otherwise noted in this standard.

**23.85.790 NFPA Standard 130 Section 6.3.1.1.3 amended – Trainway Walking Surfaces**

Section 6.3.1.1.3 of NFPA Standard 130 is hereby amended to read as follows:

**6.3.1.1.3 Walking Surfaces.** Walking surfaces designated for evacuation of passengers shall be constructed of noncombustible materials. Walking surfaces shall have a slip-resistant surface and be securely attached.

**23.85.795 NFPA Standard 130 Section 6.3.3.2.11 amended – Emergency Power - Enclosed Trainways**

Section 6.3.3.2.11 of NFPA Standard 130 is hereby amended to read as follows:

**6.3.3.2.11 Emergency Power – Enclosed Trainways.** Enclosed trainways shall be such that, in the event of failure of the normal supply to, or within, the system, standby (legally required) and emergency power shall be provided in accordance with Bellevue City Code Section 23.10.403, Article 700 of *NFPA 70* as amended by the Washington Cities Electrical code, and Chapter 4 of NFPA 110 and the follow special provisions:

Power distribution from the emergency source to the emergency transfer switch shall be by an independent route from the normal power source.

If the emergency power system is a generator set inside a building, the system shall be located in a separate room enclosed with 2-hour fire barriers constructed in accordance with International Building Code Section 707 or horizontal assemblies constructed in accordance with International Building Code Section 712, or both, and shall be in a separate room from the normal power source including transformers and distribution equipment.

If the emergency power system is a generator then system supervision with manual start and transfer features shall be provided at the fire command center. Fire pumps shall comply with NFPA 20 and NFPA 70 Article 695.

The supply system for emergency purposes, in addition to the normal services to the trainway, shall be one or more of the types of systems described in subsections 700.12(A) through 700.12(E) of *NFPA 70*.

**6.3.3.2.11.1** Systems identified in Bellevue City Code Section 23.10.403 shall be connected to the emergency power system:

**23.85.800 NFPA Standard 130 Section 6.5.2 amended – Standpipes - Enclosed Trainways**

Section 6.5.2 of NFPA Standard 130 is hereby amended to read as follows:

**6.5.2.1** An approved fire standpipe system shall be provided for fixed guideway transit or passenger rail system tramways where physical factors prevent or impede access to the water supply or fire apparatus, if required by the authority having jurisdiction.

**6.5.2.1.1** Class I or Class III standpipe systems shall be installed in trainways in accordance with NFPA 14 except as modified herein

**6.5.2.1.2** Standpipe systems shall not be required to be enclosed in fire-rated construction, provided the following conditions are met:

- (1) The system is cross-connected or fed from two locations.
- (2) Isolation valves are installed not more than 800 ft. apart

**6.5.2.2** Standpipes shall be permitted to be of the dry type with the approval of the authority having jurisdiction.

**6.5.2.3** Standpipe systems shall be provided with an approved water supply capable of supplying the system demand for a minimum of 1 hour.

**6.5.2.3.1** Acceptable water supplies shall include the following:

- (1) Approved municipal or approved privately owned water works systems that have adequate pressure, flow rate, and level of integrity
- (2) Automatic or manually controlled fire pumps that are connected to an approved water source
- (3) Pressure-type or gravity-type storage tanks that are installed in accordance with NFPA 22

**6.5.2.4** Identification numbers and letters conforming to the sectional identification numbers and letters of the fixed guideway transit or passenger trainway system shall be provided at each surface fire department connection and at each hose valve on the standpipe lines.

**6.5.2.4.1** Identifying signs shall be affixed to underground or enclosed trainway walls at each hose outlet valve or shall be painted directly on the standpipe in white letters next to each hose outlet valve.

**6.5.2.4.2** Exposed tunnel standpipe lines and identification signs shall be painted as required by the authority having jurisdiction.

**6.5.2.4.3** Hydraulic design information signs shall be provided at each fire department connection indicating the residual inlet pumping pressure(s) required for the hydraulically most remote and/or other selected hose connection outlet location(s).

**6.5.2.5** A fire department access road shall extend to within 100 ft. of the fire department connection.

**6.5.2.6** Four-way 2.5 inch fire department connections shall be provided at all emergency access points.

**6.5.2.7** Standpipes shall be sized to provide 1000 gpm. Hydraulic calculations shall be based on 500 gpm at 150 psi at the hydraulically most remote hose connection, with a simultaneous flow of 500 gpm at the next hydraulically most remote hose connection. The maximum calculated pressure at any point in the system shall not exceed 350 psi.

**6.5.2.8** Standpipes shall be interconnected at all tunnel cross passageways and within the stations, with isolation valves provided for each interconnection.

**6.5.2.9** Hose connection outlets shall be provided at maximum 200 feet



spacing.

**6.6.7.6** Tanks shall be abandoned in accordance with the provisions of Chapter 34 of the International Fire Code.

**23.85.810 NFPA Standard 130 Section 7.2.4 amended – Emergency Ventilation System Design**

Section 7.2.4 of NFPA Standard 130 is hereby amended to read as follows:

**7.2.4** The design analysis shall address the performance of the system with one fan out-of-service.

**23.85.820 NFPA Standard 130 Section 7.7.1 amended – Emergency Ventilation Power System Design**

Section 7.7.1 of NFPA Standard 130 is hereby amended to read as follows:

**7.7.1** The design of the power for the emergency ventilation system shall comply with the requirements of Bellevue City Code Bellevue City Code Section 23.10.403, Article 700 and 701 of *NFPA 70* as amended by the Washington Cities Electrical Code.

**23.85.830 NFPA Standard 130 Section 8.8.3.1 amended – Trainway Illumination – Emergency Lighting**

Section 8.8.3.1 of NFPA Standard 130 is hereby amended to read as follows:

**8.8.3.1** In case of an emergency a means shall be provided to allow passengers to safely board the vehicle (rescue train) from a walk surface or other suitable area under the supervision of authorized employees. Emergency lighting facilities shall be provided such that the level of illumination of the means of egress confirms to the level of illumination determined necessary by the authority having jurisdiction or with the following:

- (1) A minimum average illumination level of 10 lx (0.93 ft-candle), measured at the floor level adjacent to each interior door, with each interior door providing access to an exterior door (such as a door opening into a vestibule) or other emergency egress facility
- (2) A minimum average illumination level of 10 lx (0.93 ft-candle), measured 610 mm (24 in.) above floor level along the center of each aisle and passageway
- (3) A minimum illumination level of 1 lx (0.093 ft-candle), measured 610 mm (24 in.) above floor level at any point along the center of each aisle and passageway

# ORIGINAL

**23.85.850 NFPA Standard 130 Section 10.3.2 amended – Emergency Responder Radio Coverage**

Section 10.3.2 of NFPA Standard 130 is hereby amended to read as follows:

**10.3.2** -Emergency Responder radio coverage shall be provided throughout all tunnels, fixed guideways, stations and ancillary spaces in accordance with Bellevue City Code Section 23.11.510

**23.85.860 NFPA Standard 130 Section 10.6.1 amended – Station Public Address System**

Section 10.6.1 of NFPA Standard 130 is hereby amended to read as follows:

**10.6.1.** All stations shall have a Public Address system for communicating with passengers and employees designed in accordance with Chapter 24 of NFPA 72. (For communication requirements for vehicles, see 8.9.2.)

Section 2. This ordinance shall take effect and be in force five (5) days after passage and legal publication.

Passed by the City Council this 17<sup>th</sup> day of June, 2013,  
and signed in authentication of its passage this 17<sup>th</sup> day of June, 2013.

(SEAL)

  
Conrad Lee, Mayor

Approved as to form:

Lori M. Riordan, City Attorney

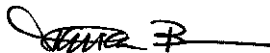
  
Monica A. Buck, Assistant City Attorney

Attest:

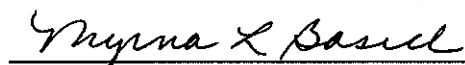
  
Myrna L. Basich, City Clerk

Published June 20, 2013,